

Motion Sensor COB LED Flood Lights



Specification:

- Nicely treated die-casting ADC12 aluminum alloy housing
- 4mm tempered glass cover, strong protection and good optical function
- Waterproof: IP65
- Operating Temperature: -20-50°C
- Storage Temperature: -40-60°C

Application:

Garden, residential area, landscape, architectural decorative lighting, roads and other places.



● Dimensions

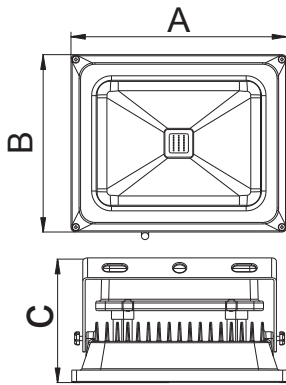

Model No.	Product Dimension (mm)		
	A	B	C
ENFL-10W-01PIR	115	185	100
ENFL-20W-01PIR	180	140	135
ENFL-30W-01PIR	225	185	160
ENFL-50W-01PIR	285	243	170

● Data

Model No.	ENFL-10W-01PIR	ENFL-20W-01PIR	ENFL-30W-01PIR	ENFL-50W-01PIR
Input Voltage	85-265VAC, 50-60Hz			
PF	>0.5			>0.9
Power (W)	10	20	30	50
Lumen (lm)	900	1800	2700	4500
CRI	> 70			
Beam Angle	120°			
Color	3000K / 6000K			
IP Grade	IP65			
LED	Sanan 30mil			
LED Driver	CE Driver			
Packing Dimension (mm)	30PCS 595×345×300	12PCS 415×415×330	8PCS 475×475×265	4PCS 600×310×300
Net Weight/ Gross Weight (Kg)	30PCS 14.0/16.0	12PCS 12.0/14.0	8PCS 12.6/14.6	4PCS 10.0/12.0

● User Instruction:

1. Rated operational voltage: AC85~265V 50/60HZ. The input voltage should be stable to avoid large fluctuation. It should be no more than rated operational voltage.
2. Ambient temperature for storage: $-40^{\circ}\text{C}\sim+60^{\circ}\text{C}$
Ambient temperature for working: $-20^{\circ}\text{C}\sim+50^{\circ}\text{C}$
The best ambient temperature for working: $-0^{\circ}\text{C}\sim+30^{\circ}\text{C}$
3. There are glass fittings for the light. Please handle with care. To avoid the glass from being broken, heavy loading is forbidden.

● Installation Instruction:

It is suggested that the LED flood lights should be installed by professionals following the instructions. Otherwise, the following consequences may result.

1. The light given out by the flood light cannot be fully displayed. The beam angle is inappropriate.
2. The light cannot work normally
3. The danger of electric shock.

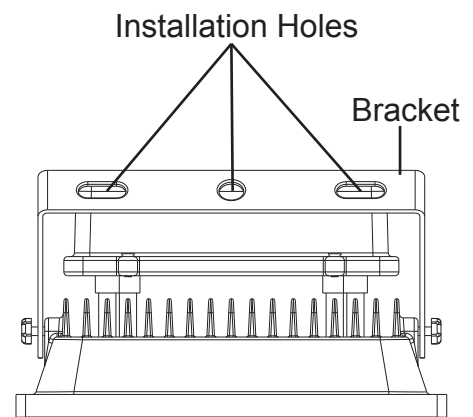

Step 1: Inspect installation position

First check whether the support or screws of the installation position can bear the weight of 1.5 times more than the body weight of the light. If not, please do not install.

Step 2: Fix the light

If the support for installation is steel, aluminum or iron bracket, please drill three holes in the metal support. The location of the holes is the same as what is on the bracket. Please align the holes on both the bracket of the light and the metal bracket. Then lock them with screws. If the place for installation is cement or concrete on flat surface, please drill holes with jackhammer on the corresponding position of the mounting surface. Then fix the light with setscrews of more than $\Phi 10\text{MM}$.

1. Pass the screw through the bracket



2. Lock the screw



3. Install completed



● Debugging sensor status:

1. Sensor angle can be adjusted up and down to set different induction range.
Shown in figure A and figure B
2. Set the function button below the sensor. Shown in figure C
TIME – Lighting time setting
LUX – Environment brightness setting
3. Set the TIME in 5 seconds and the LUX in the daytime position, then can be inductive range test mold
4. Turn on the power, then the lamps will be in the status of warming up the machine, people need to leave the sensing area, probably the lamp will light 1-2 minutes, then automatically turn off
5. Enter the sensing range by walking around the speed of about 0.5 meters per second, then the sensor is sensitive to the human body, and automatically turn on the lights, stationary. After about 5 seconds, turn off the lights, then move again. Such a test by setting the sensor point of view to determine the range of induction.

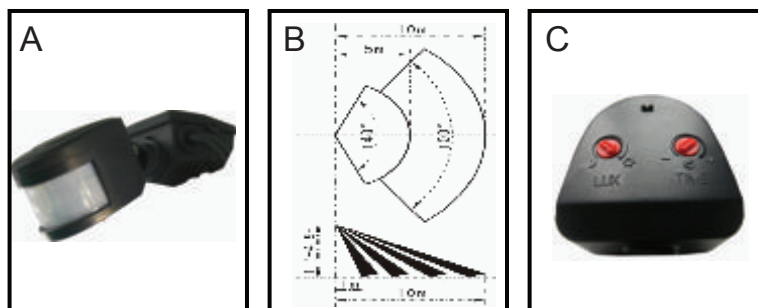

● Sensor automatic inductive setting:

When the above installation debugging completed, the lamps need to be set for automatic sensor lighting mode

1. When adjust the lighting, transferred the adjustable twist from [5 seconds] slowly clockwise rotation
Enter into the sensor detection range, after confirm the lights turn on, please leave immediately (if the person remain within the sensing range, it will result in the lighting time extended)
2. Change the light adjustable twist from [day] rotate clockwise to do [day and night lighting, dusk began lighting or only night lighting] function setting
The installation should be in actual position environment setting

- ☾ Only the night will lighting
- ⚙ Day and night both lighting

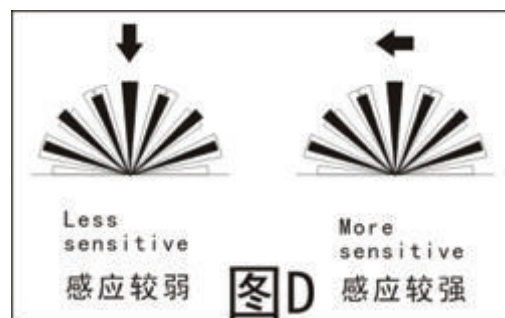

For the sensor cross-section occasions, the sensor sensitivity is high. For the sensor straight forward occasions, sensor sensitivity becomes relatively low.